

PR-R8572318xxx PRESSALIT ELECTRIC HEIGHT ADJUSTABLE SHOWER CHANGE TABLE SCT3000

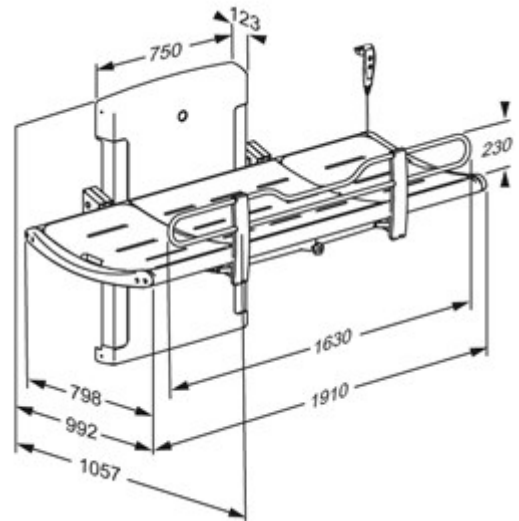

DESCRIPTION

The Pressalit electronic shower change table is designed to provide a stable platform for showering and changing adults and children with reduced mobility.

The SCT3000 electric shower change table has a height adjustment of 700mm from 300 mm - 1000mm using a wired hand control. The unit comes with integrated gas cylinders that enable the table to be folded out of the way when not in use to maximise floor space.

The ergonomically designed safety rails have a practical lower central section, which provides better access and work environment for the carer while transferring, showering, drying, changing and dressing the user.

A water collection tray with integrated water outlet prevents water from splashing on carers or the floor. The flexible hose (Ø32 mm) attached to the center mounted outlet of the water collection tray, can be connected to either an outlet in the floor or on the wall.

NOTE: It is the responsibility of the installer to ensure that suitable wall fasteners are used. Product does not come with fixing kit.

PRODUCT

Material: Powder-lacquered stainless steel aluminium and plastic. Pads in polyurethane foam

Noise Level: 48dB

Speed Up mm: 15mm/s

Speed down mm: 20 mm/s

Power consumption by maximum load, watt: 390 W

Power consumption by standby: 2 W

Mains connections 230V / 50Hz

Maximum user weight: 227kg

Safe Working load: 237kg

When the table is loaded with 227kg each mounting bolt supports 29.5kg.

MODELS

PR-R8572318301 - Pressalit Electric Shower Change Table 1910mm With Graphite Grey Coloured Pads.

PR-R8572318299 - Pressalit Electric Shower Change Table 1910mm With Sapphire Blue Coloured Pads.

PR-R8572313301 - Pressalit Electric Shower Change Table 1410mm With Graphite Grey Coloured Pads.

PR-R8572313299 - Pressalit Electric Shower Change Table 1410mm With Sapphire Blue Coloured Pads